

> RGA

AIR-WATER CHILLERS AND HEAT PUMPS FOR OUTDOOR INSTALLATION



Available range

Unit type

IR	Chiller
IP	Heat pump (reversible on the refrigerant side)
BR	Chiller Brine
BP	Heat pump Brine (reversible on the refrigerant side)

Version

VB	Base version
VD	Desuperheater version
VR	Total recovery version

Acoustic setting up

AB	Base setting up
AS	Low noise setting up
AX	eXtra low noise setting up

Source temperature level

M	Medium temperature level
A	High temperature level

Unit description

This series of air-water chillers and heat pumps satisfies the cooling and heating requirements of residential plants of medium size.

All the units are suitable for outdoor installation and can be applied to fan coil plants, radiant floor plants and high efficiency radiators plants.

The refrigerant circuit, contained in a compartment protected from the air flow to simplify the maintenance operations, is equipped with scroll compressors mounted on damper supports, brazed plate heat exchanger, thermostatic expansion valve (standard for IR) or electronic expansion valve (standard for IP / option for IR),

reverse cycle valve, dehydrator filter, axial fans with safety protection grilles, finned coil made of copper pipes and aluminium louvered fins with subcooling section. The circuit is protected by a safety gas valve, high and low pressure switches and differential pressure switch on the plate heat exchanger. The plate heat exchanger and all the hydraulic pipes are thermally insulated in order to avoid condensate generation and to reduce thermal losses.

All the units can be equipped with variable speed fans control that allows the units to operate with low outdoor temperatures in cooling and high outdoor temperature in heating and permits to reduce noise emissions in such operating conditions.

The low noise acoustic setting up (AS) is obtained, starting from the base setting up (AB), reducing the rotational speed of the fans and mounting sound jackets on the compressors and the technical compartment is clad with soundproofing material of suitable thickness.

The eXtra low noise acoustic setting up (AX) is obtained, starting from the low noise setting up (AS), further reducing the rotational speed of the fans and using finned coil with bigger surface.

All the units are supplied with a management and control electrical panel containing general switch, phase presence and correct sequence controller, microprocessor controller with display and all the other electrical components with IP54 minimum protection degree.

All the units are accurately built and individually tested in the factory. Only electric and hydraulic connections are required for installation.

Options

Storing and pumping module available in the configurations :

- Storage tank arranged as buffer on the flow or as primary-secondary buffer

- 1 or 2 pumps
- standard or high head pump
- modulating pump

Expansion valve

- thermostatic
- electronic (standard for IP)

Compressor starting

- standard (contactors)
- soft starter

Fans control

- on-off control
- modulating control (condensation / evaporation control)

Compressor power factor correction

Electrical load protection

- fuses
- thermal magnetic circuit breakers

Coil condensate tray

Accessories

Rubber vibration dampers

Spring vibration dampers

Coil protection grilles

Tank antifreeze electrical heater

Remote control

Modbus serial interface on RS485

Programmer clock

Phase sequence and voltage controller

Low temperature kit (standard for IP)

High and low pressure gauges

High temperature thermostat

Coil shut off valves

Outdoor air sensor

Water flow switch

Victaulic hydraulic fittings

Acoustic performances

Base setting up (AB)	40.2	50.2	60.2	70.2	80.2	90.2	100.2	115.2	130.2	145.2	160.2	180.2	200.2	
Sound power level ^(E)	82	82	83	84	84	85	85	85	86	87	87	88	88	dB(A)
Sound pressure level at 1 meter	64	64	65	66	66	67	67	67	68	69	69	69	69	dB(A)
Sound pressure level at 5 meters	55	55	56	57	57	58	58	58	59	60	60	61	61	dB(A)
Sound pressure level at 10 meters	50	50	51	52	52	53	53	53	54	55	55	56	56	dB(A)
Low noise setting up (AS)	40.2	50.2	60.2	70.2	80.2	90.2	100.2	115.2	130.2	145.2	160.2	180.2	200.2	
Sound power level ^(E)	79	79	80	81	81	82	82	82	83	84	84	85	85	dB(A)
Sound pressure level at 1 meter	61	61	62	63	63	64	64	64	65	66	66	66	66	dB(A)
Sound pressure level at 5 meters	52	52	53	54	54	55	55	55	56	57	57	58	58	dB(A)
Sound pressure level at 10 meters	47	47	48	49	49	50	50	50	51	52	52	53	53	dB(A)
eXtra low noise setting up (AX)	40.2	50.2	60.2	70.2	80.2	90.2	100.2	115.2	130.2	145.2	160.2	180.2	200.2	
Sound power level ^(E)	77	77	78	79	79	80	80	80	81	82	82	83	83	dB(A)
Sound pressure level at 1 meter	59	59	60	61	61	62	62	62	63	64	64	64	64	dB(A)
Sound pressure level at 5 meters	50	50	51	52	52	53	53	53	54	55	55	56	56	dB(A)
Sound pressure level at 10 meters	45	45	46	47	47	48	48	48	49	50	50	51	51	dB(A)

(E): EUROVENT certified data

The acoustic performances are referred to units operating in cooling mode at nominal conditions A35W7.

Unit placed in free field on reflecting surface (directional factor equal to 2).

The sound power level is measured according to ISO 9614 standard.

The sound pressure level is calculated according to ISO 3744 and is referred to a distance of 1/5/10 metres from the external surface of the unit.

Technical data

Unit	40.2	50.2	60.2	70.2	80.2	90.2	100.2	115.2	130.2	145.2	160.2	180.2	200.2			
Power supply	400 - 3+N - 50						400 - 3 - 50						V-ph-Hz			
Compressor type	scroll													-		
N° compressors / N° refrigerant circuits	2 / 1													n°		
Plant side heat exchanger type	stainless steel brazed plates													-		
Source side heat exchanger type	finned coil													-		
Fans type	axial													-		
N° fans	2			3			2			3			4			n°
Tank volume	200						400						460			l
Hydraulic fittings	2" VICTAULIC						2" 1/2 VICTAULIC									-

Electrical data

Standard unit	40.2	50.2	60.2	70.2	80.2	90.2	100.2	115.2	130.2	145.2	160.2	180.2	200.2	
FLA - Full load current at maximum tolerated conditions	40,2	45,7	53,3	58,7	69,6	75,5	90,0	97,9	106	123	136	159	170	A
FLI - Full load power input at maximum tolerated conditions	21,6	24,4	28,4	31,0	36,2	44,0	55,0	60,5	66,0	75,7	83,3	95,4	103	kW
MIC - Maximum instantaneous current of the unit	134	143	149	173	213	264	259	267	267	348	361	355	391	A
MIC SS - Maximum instantaneous current of the unit with soft starter options	89,3	96,3	101	117	143	174	175	183	183	200	246	248	272	A
Unit with high head modulating pump	40.2	50.2	60.2	70.2	80.2	90.2	100.2	115.2	130.2	145.2	160.2	180.2	200.2	
FLA - Full load current at maximum tolerated conditions	46,3	51,8	59,4	64,8	76,0	81,6	96,1	107	115	132	147	169	180	A
FLI - Full load power input at maximum tolerated conditions	25,1	27,9	31,9	34,5	42,1	47,5	58,5	65,1	70,6	80,3	89,6	102	109	kW
MIC - Maximum instantaneous current of the unit	140	150	155	179	219	270	265	276	276	357	372	365	402	A
MIC SS - Maximum instantaneous current of the unit with soft starter options	95,4	102	107	123	150	180	181	192	192	209	257	258	282	A

Operative range

Temperature	Unit type	Cooling		Heating		
		min	max	min	max	
Outdoor air inlet temperature	IR, BR, IP, BP	-10*	52**	-10	40*	(°C)
Water outlet temperature	IR, IP	5	25	30	55	(°C)
Water outlet temperature	BR, BP	-12	5	30	55	(°C)
Water outlet temperature (VD)	IR, BR, IP, BP	30	70	30	70	(°C)
Water outlet temperature (VR)	IR, BR	30	55	-	-	(°C)

* with fans modulating control option (condensation / evaporation control)

** with ATC outdoor high temperature protection function

VD and VR versions

These units allow to recover the heating power, otherwise wasted on air, through an additional heat exchanger. The **Desuperheater Version (VD)** allow the hot water production at temperatures between 30 and 70°C through the partial heat recovery of the condensation heat. **The Total Recovery Version (VR)** allows the cold water production and, at the same time, the hot water production at temperatures between 30 and 55°C through the total recovery of the condensation heat.

Desupeheater Version (VD) - NET NOMINAL performances

IR	Base setting up (AB)	40.2	50.2	60.2	70.2	80.2	90.2	100.2	115.2	130.2	145.2	160.2	180.2	200.2	
A35W7 - W45	Cooling capacity	46,8	55,1	60,3	71	81,1	93,8	105	115	130	148	163	185	206	kW
	Total power input	15,3	18,3	20,3	23,4	27,3	31,8	35,1	38,9	44	50,3	55,8	63	69,9	kW
	EER	3,05	3	2,98	3,03	2,97	2,95	2,99	2,96	2,95	2,94	2,92	2,94	2,95	W/W
	HRE	3,93	3,86	3,84	3,88	3,83	3,8	3,86	3,85	3,83	3,81	3,8	3,82	3,83	W/W
	Water flow rate	2,25	2,66	2,91	3,42	3,91	4,52	5,06	5,54	6,26	7,12	7,84	8,93	9,94	l/s
	Water pressure drop	43	60	59	55	54	52	50	47	52	51	52	52	54	kPa
	Heating recovery capacity	13,5	15,7	17,6	20	23,6	27,1	30,4	34,4	38,4	44	49,3	55,4	61,3	kW
	Water flow rate recovery	0,65	0,75	0,84	0,96	1,13	1,29	1,45	1,64	1,83	2,1	2,36	2,65	2,93	l/s
	Water pressure drop recovery	6	9	11	14	19	15	18	11	14	18	22	18	21	kPa
	IP	Base setting up (AB)	40.2	50.2	60.2	70.2	80.2	90.2	100.2	115.2	130.2	145.2	160.2	180.2	200.2
Cooling capacity		45,3	54,5	59,3	69,3	76,5	92,1	102	113	126	143	159	183	204	kW
Total power input		15,1	18,5	20,1	23,5	26,4	31,5	34,9	38,7	43,4	49,1	54,9	62,1	69,5	kW
EER		3	2,94	2,94	2,95	2,9	2,92	2,93	2,92	2,9	2,91	2,89	2,95	2,94	W/W
HRE		3,86	3,76	3,79	3,78	3,77	3,75	3,77	3,78	3,76	3,77	3,75	3,8	3,77	W/W
Water flow rate		2,18	2,63	2,86	3,34	3,68	4,43	4,92	5,45	6,07	6,88	7,64	8,84	9,84	l/s
Water pressure drop		41	59	57	53	48	50	47	46	49	48	49	51	53	kPa
Heating recovery capacity		13	15,2	17	19,4	22,9	26,2	29,2	33,2	37,1	42,4	47,5	52,4	58,1	kW
Water flow rate recovery		0,62	0,73	0,81	0,93	1,09	1,25	1,4	1,59	1,77	2,03	2,27	2,5	2,78	l/s
Water pressure drop recovery		6	8	10	13	18	14	17	10	13	17	21	16	19	kPa

Total Recovery Version (VR) - NET NOMINAL performances

IR	Base setting up (AB)	40.2	50.2	60.2	70.2	80.2	90.2	100.2	115.2	130.2	145.2	160.2	180.2	200.2	
A35W7 - W45	Cooling capacity	46,8	55,1	60,3	71	81,1	93,8	105	115	130	148	163	185	206	kW
	Total power input	13,9	16,9	18,4	21,4	25,3	27,9	31,1	35	40	44,4	49,9	55,3	62,1	kW
	EER	3,36	3,25	3,28	3,31	3,2	3,36	3,38	3,29	3,25	3,33	3,26	3,35	3,32	W/W
	HRE	7,67	7,46	7,52	7,58	7,35	7,67	7,71	7,52	7,45	7,61	7,47	7,65	7,59	W/W
	Water flow rate	2,25	2,66	2,91	3,42	3,91	4,52	5,06	5,54	6,26	7,12	7,84	8,93	9,94	l/s
	Water pressure drop	43	60	59	55	54	52	50	47	52	51	52	52	54	kPa
	Heating recovery capacity	60	71,2	77,8	91,4	105	120	135	148	168	190	210	238	265	kW
	Water flow rate recovery	2,87	3,4	3,72	4,37	5,02	5,73	6,45	7,07	8,03	9,08	10	11,4	12,7	l/s
	Water pressure drop recovery	35	49	41	45	50	48	52	47	52	51	52	55	55	kPa

Data declared according to EN 14511. The values are referred to units without options and accessories.

EER (Energy Efficiency Ratio) = ratio of the total cooling capacity to the effective power input of the unit

HRE (Heat Recovery Efficiency) = ratio of the total capacity of the system (heating plus cooling capacity) to the effective power input

A35W7 - W45 = source : air in 35°C d.b. / plant : water in 12°C out 7°C / Recovery : water in 40°C out 45°C

CONTROL SYSTEM

The units are equipped with a controller designed to ensure energy saving and unit efficiency. Available functions :

- Adaptive function
- Dynamic defrost
- Sound management
- Climatic control in heating and in cooling mode
- Economy function
- Demand limit
- Integrative heating
- Remote stand by
- Remote cooling-heating



DIMENSIONS - MINIMUM OPERATING AREA - WEIGHT

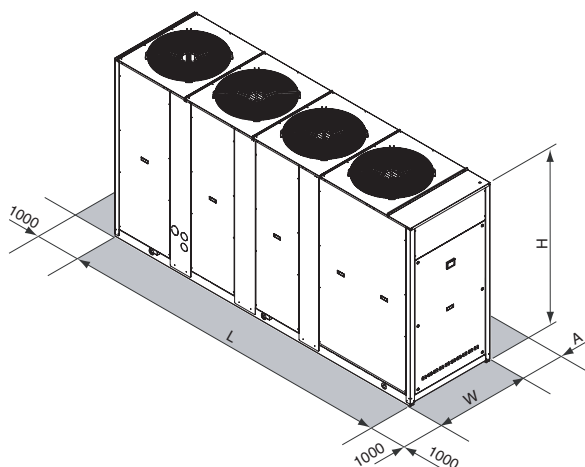

	40.2	50.2	60.2	70.2	80.2	90.2	100.2	115.2	130.2	145.2	160.2	180.2	200.2	
L			2501				3343			3343			4097	mm
W			954				1104			1104			1104	mm
H			1930				1793			2193			2193	mm
A			1600							2000				mm
Operating maximum weight*	1027	1031	1053	1088	1107	1587	1668	1749	1833	1891	1935	2260	2296	kg

* Weight refers to the unit IP with tank and pumping module 2 pumps.

> RGA HE

AIR-WATER CHILLERS AND HEAT PUMPS
FOR OUTDOOR INSTALLATION



Available range

Unit type

IR	Chiller
IP	Heat pump (reversible on the refrigerant side)
BR	Chiller Brine
BP	Heat pump Brine (reversible on the refrigerant side)

Version

VB	Base version
VD	Desuperheater version
VR	Total recovery version

Acoustic setting up

AB	Base setting up
AS	Low noise setting up
AX	eXtra low noise setting up

Source temperature level

M	Medium temperature level
A	High temperature level

Unit description

This series of air-water chillers and heat pumps satisfies the cooling and heating requirements of residential plants of medium size.

All the units are suitable for outdoor installation and can be applied to fan coil plants, radiant floor plants and high efficiency radiators plants.

The refrigerant circuit, contained in a compartment protected from the air flow to simplify the maintenance operations, is equipped with scroll compressors mounted on damper supports, brazed plate heat exchanger, thermostatic expansion valve (standard for IR) or electronic expansion valve (standard for IP / option for IR),

reverse cycle valve, dehydrator filter, axial fans with safety protection grilles, finned coil made of copper pipes and aluminium louvered fins with subcooling section. The circuit is protected by a safety gas valve, high and low pressure switches and differential pressure switch on the plate heat exchanger. The plate heat exchanger and all the hydraulic pipes are thermally insulated in order to avoid condensate generation and to reduce thermal losses.

All the units can be equipped with variable speed fans control that allows the units to operate with low outdoor temperatures in cooling and high outdoor temperature in heating and permits to reduce noise emissions in such operating conditions.

The low noise acoustic setting up (AS) is obtained, starting from the base setting up (AB), reducing the rotational speed of the fans and mounting sound jackets on the compressors and the technical compartment is clad with soundproofing material of suitable thickness.

The eXtra low noise acoustic setting up (AX) is obtained, starting from the low noise setting up (AS), further reducing the rotational speed of the fans and using finned coil with bigger surface.

All the units are supplied with a management and control electrical panel containing general switch, phase presence and correct sequence controller, microprocessor controller with display and all the other electrical components with IP54 minimum protection degree.

All the units are accurately built and individually tested in the factory. Only electric and hydraulic connections are required for installation.

Options

Storing and pumping module available in the configurations :

- Storage tank arranged as buffer on the flow or as primary-secondary buffer
- 1 or 2 pumps
- standard or high head pump
- modulating pump

Expansion valve

- thermostatic
- electronic (standard for IP)

Compressor starting

- standard (contactors)
- soft starter

Fans control

- on-off control
- modulating control (condensation / evaporation control)

Compressor power factor correction

Electrical load protection

- fuses
- thermal magnetic circuit breakers

Coil condensate tray

Accessories

Rubber vibration dampers

Spring vibration dampers

Coil protection grilles

Tank antifreeze electrical heater

Remote control

Modbus serial interface on RS485

Programmer clock

Phase sequence and voltage controller

Low temperature kit (standard for IP)

High and low pressure gauges

High temperature thermostat

Coil shut off valves

Outdoor air sensor

Water flow switch

Victaulic hydraulic fittings

Acoustic performances

Base setting up (AB)	40.2	50.2	60.2	70.2	80.2	90.2	100.2	115.2	130.2	145.2	160.2	180.2	
Sound power level ^(E)	82	82	83	84	85	85	85	85	86	87	87	88	dB(A)
Sound pressure level at 1 meter	64	64	65	66	67	67	67	67	68	69	69	69	dB(A)
Sound pressure level at 5 meters	55	55	56	57	58	58	58	58	59	60	60	61	dB(A)
Sound pressure level at 10 meters	50	50	51	52	53	53	53	53	54	55	55	56	dB(A)
Low noise setting up (AS)	40.2	50.2	60.2	70.2	80.2	90.2	100.2	115.2	130.2	145.2	160.2	180.2	
Sound power level ^(E)	79	79	80	81	82	82	82	82	83	84	84	85	dB(A)
Sound pressure level at 1 meter	61	61	62	63	64	64	64	64	65	66	66	66	dB(A)
Sound pressure level at 5 meters	52	52	53	54	55	55	55	55	56	57	57	58	dB(A)
Sound pressure level at 10 meters	47	47	48	49	50	50	50	50	51	52	52	53	dB(A)
eXtra low noise setting up (AX)	40.2	50.2	60.2	70.2	80.2	90.2	100.2	115.2	130.2	145.2	160.2	180.2	
Sound power level ^(E)	77	77	78	79	80	80	80	80	81	82	82	83	dB(A)
Sound pressure level at 1 meter	59	59	60	61	62	62	62	62	63	64	64	64	dB(A)
Sound pressure level at 5 meters	50	50	51	52	53	53	53	53	54	55	55	56	dB(A)
Sound pressure level at 10 meters	45	45	46	47	48	48	48	48	49	50	50	51	dB(A)

(E): EUROVENT certified data

The acoustic performances are referred to units operating in cooling mode at nominal conditions A35W7.

Unit placed in free field on reflecting surface (directional factor equal to 2).

The sound power level is measured according to ISO 9614 standard.

The sound pressure level is calculated according to ISO 3744 and is referred to a distance of 1/5/10 metres from the external surface of the unit.

Technical data

Unit	40.2	50.2	60.2	70.2	80.2	90.2	100.2	115.2	130.2	145.2	160.2	180.2	
Power supply	400 - 3+N - 50				400 - 3 - 50								V-ph-Hz
Compressor type	scroll												-
N° compressors / N° refrigerant circuits	2 / 1												n°
Plant side heat exchanger type	stainless steel brazed plates												-
Source side heat exchanger type	finned coil												-
Fans type	axial												-
N° fans	2	3		2				3		4			n°
Tank volume	200				400				460				l
Hydraulic fittings	2" VICTAULIC				2" 1/2 VICTAULIC								-

Electrical data

Standard unit	40.2	50.2	60.2	70.2	80.2	90.2	100.2	115.2	130.2	145.2	160.2	180.2	
FLA - Full load current at maximum tolerated conditions	40,2	45,7	53,3	58,7	69,6	75,5	90,0	97,9	106	123	136	159	A
FLI - Full load power input at maximum tolerated conditions	21,6	24,4	28,4	31,0	36,2	44,0	55,0	60,5	66,0	75,7	83,3	95,4	kW
MIC - Maximum instantaneous current of the unit	134	143	149	173	213	264	259	267	267	348	361	355	A
MIC SS - Maximum instantaneous current of the unit with soft starter options	89,3	96,3	101	117	143	174	175	183	183	200	246	248	A
Unit with high head modulating pump	40.2	50.2	60.2	70.2	80.2	90.2	100.2	115.2	130.2	145.2	160.2	180.2	
FLA - Full load current at maximum tolerated conditions	46,3	51,8	59,4	64,8	76,0	81,6	96,1	107	115	132	147	169	A
FLI - Full load power input at maximum tolerated conditions	25,1	27,9	31,9	34,5	42,1	47,5	58,5	65,1	70,6	80,3	89,6	102	kW
MIC - Maximum instantaneous current of the unit	140	150	155	179	219	270	265	276	276	357	372	365	A
MIC SS - Maximum instantaneous current of the unit with soft starter options	95,4	102	107	123	150	180	181	192	192	209	257	258	A

Operative range

Temperature	Unit type	Cooling		Heating		
		min	max	min	max	
Outdoor air inlet temperature	IR, BR, IP, BP	-10*	52**	-15	40*	(°C)
Water outlet temperature	IR, IP	5	25	30	55	(°C)
Water outlet temperature	BR, BP	-12	5	30	55	(°C)
Water outlet temperature (VD)	IR, BR, IP, BP	30	70	30	70	(°C)
Water outlet temperature (VR)	IR, BR	30	55	-	-	(°C)

* with fans modulating control option (condensation / evaporation control)

** with ATC outdoor high temperature protection function

VD and VR versions

These units allow to recover the heating power, otherwise wasted on air, through an additional heat exchanger.

The **Desuperheater Version (VD)** allow the hot water production at temperatures between 30 and 70°C through the partial heat recovery of the condensation heat.

The **Total Recovery Version (VR)** allows the cold water production and, at the same time, the hot water production at temperatures between 30 and 55°C through the total recovery of the condensation heat.

Desupeheater Version (VD) - NET NOMINAL performances

IR	Base setting up (AB)	40.2	50.2	60.2	70.2	80.2	90.2	100.2	115.2	130.2	145.2	160.2	180.2	
A35W7 - W45	Cooling capacity	49,1	58,1	65,5	73,3	86,7	98,6	110	125	138	159	180	205	kW
	Total power input	14,5	16,7	19,4	21,5	26,6	30,5	33,8	37,7	41,6	48,8	54,1	63,1	kW
	EER	3,38	3,47	3,38	3,41	3,26	3,24	3,27	3,32	3,32	3,26	3,32	3,24	W/W
	HRE	4,36	4,48	4,36	4,4	4,21	4,18	4,22	4,28	4,29	4,21	4,29	4,19	W/W
	Water flow rate	2,36	2,79	3,15	3,53	4,17	4,74	5,3	6,02	6,64	7,64	8,65	9,84	l/s
	Water pressure drop	26	37	36	44	34	35	37	36	38	38	41	42	kPa
	Heating recovery capacity	14,2	16,9	19	21,3	25,1	28,6	32,1	36,2	40,3	46,3	52,3	59,4	kW
	Water flow rate recovery	0,68	0,81	0,91	1,02	1,2	1,37	1,53	1,73	1,93	2,21	2,5	2,84	l/s
	Water pressure drop recovery	7	10	13	16	21	16	20	12	15	20	25	20	kPa
	IP	Base setting up (AB)	40.2	50.2	60.2	70.2	80.2	90.2	100.2	115.2	130.2	145.2	160.2	180.2
A35W7 - W45	Cooling capacity	47,1	55,8	63,1	70,4	84,6	96	107	120	133	153	173	199	kW
	Total power input	14,2	16,6	18,9	21,2	26	29,5	33	36,8	40,7	47,3	53,1	61,4	kW
	EER	3,32	3,36	3,33	3,33	3,25	3,25	3,25	3,27	3,27	3,24	3,26	3,24	W/W
	HRE	4,28	4,34	4,3	4,3	4,19	4,2	4,2	4,21	4,22	4,18	4,2	4,17	W/W
	Water flow rate	2,26	2,68	3,03	3,39	4,06	4,61	5,16	5,78	6,4	7,36	8,31	9,56	l/s
	Water pressure drop	24	34	33	41	32	33	35	33	35	35	38	40	kPa
	Heating recovery capacity	13,6	16,2	18,3	20,5	24,5	27,9	31,1	34,7	38,6	44,4	50,1	57,5	kW
	Water flow rate recovery	0,65	0,77	0,87	0,98	1,17	1,33	1,49	1,66	1,84	2,12	2,39	2,75	l/s
	Water pressure drop recovery	7	9	12	14	20	16	19	11	14	18	23	19	kPa

Total Recovery Version (VR) - NET NOMINAL performances

IR	Base setting up (AB)	40.2	50.2	60.2	70.2	80.2	90.2	100.2	115.2	130.2	145.2	160.2	180.2	
A35W7 - W45	Cooling capacity	49,1	58,1	65,5	73,3	86,7	98,6	110	125	138	159	180	205	kW
	Total power input	13,2	15,4	17,4	19,5	22,8	26,6	29,9	33,7	37,7	43	48,2	55,4	kW
	EER	3,72	3,76	3,77	3,75	3,81	3,72	3,7	3,71	3,66	3,7	3,73	3,7	W/W
	HRE	8,39	8,47	8,49	8,46	8,55	8,39	8,35	8,37	8,27	8,36	8,42	8,34	W/W
	Water flow rate	2,36	2,79	3,15	3,53	4,17	4,74	5,3	6,02	6,64	7,64	8,65	9,84	l/s
	Water pressure drop	26	37	36	44	34	35	37	36	38	38	41	42	kPa
	Heating recovery capacity	61,7	72,7	82,1	91,9	108	124	139	157	174	200	226	257	kW
	Water flow rate recovery	2,95	3,47	3,92	4,39	5,16	5,92	6,64	7,5	8,31	9,56	10,8	12,3	l/s
	Water pressure drop recovery	34	47	42	41	48	47	52	49	51	50	54	53	kPa

Data declared according to **EN 14511**. The values are referred to units without options and accessories.

EER (Energy Efficiency Ratio) = ratio of the total cooling capacity to the effective power input of the unit

HRE (Heat Recovery Efficiency) = ratio of the total capacity of the system (heating plus cooling capacity) to the effective power input

A35W7 - W45 = source : air in 35°C d.b. / plant : water in 12°C out 7°C / Recovery : water in 40°C out 45°C

CONTROL SYSTEM

The units are equipped with a controller designed to ensure energy saving and unit efficiency. Available functions :

- Adaptive function
- Dynamic defrost
- Sound management
- Climatic control in heating and in cooling mode
- Economy function
- Demand limit
- Integrative heating
- Remote stand by
- Remote cooling-heating



DIMENSIONS - MINIMUM OPERATING AREA - WEIGHT

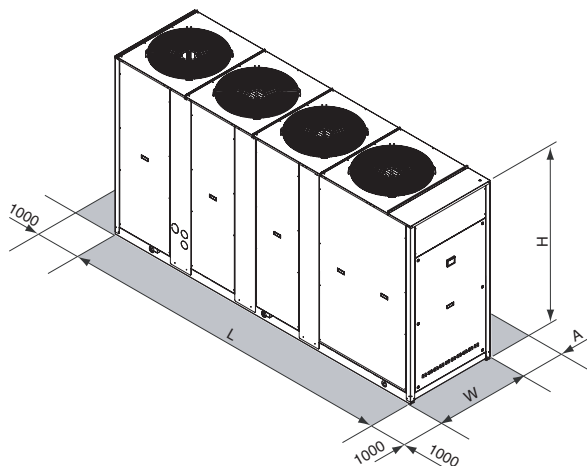

	40.2	50.2	60.2	70.2	80.2	90.2	100.2	115.2	130.2	145.2	160.2	180.2	
L	2501			3343			3343			4097			mm
W	954			1104			1104			1104			mm
H	1930			1793			2193			2193			mm
A	1600			2000			2000			2000			mm
Operating maximum weight*	1068	1072	1095	1132	1569	1650	1735	1877	1906	1967	2292	2350	kg

* Weight refers to the unit IP with tank and pumping module 2 pumps.

> RGA ST

AIR-WATER CHILLERS AND HEAT PUMPS FOR OUTDOOR INSTALLATION



Available range

Unit type

- IR Chiller
- IP Heat pump
(reversible on the refrigerant side)
- BR Chiller Brine
- BP Heat pump Brine
(reversible on the refrigerant side)

Version

- VB Base version
- VD Desuperheater version
(with plate heat exchanger)
- VR Total recovery version
(with plate heat exchanger)

Acoustic setting up

- AB Base setting up
- AS Low noise setting up
- AX eXtra low noise setting up

Source temperature level

- M Medium temperature level
- A High temperature level

Unit description

This series of air-water chillers and heat pumps satisfies the cooling and heating requirements of residential plants of medium size.

All the units are suitable for outdoor installation and can be applied to fan coil plants, radiant floor plants and high efficiency radiators plants.

The refrigerant circuit, contained in a compartment protected from the air flow to simplify the maintenance operations, is equipped with scroll compressors mounted on damper supports, shell and tube heat exchanger with threaded or vicia fittings (according to the model),

thermostatic expansion valve (standard for IR) or electronic expansion valve (standard for IP / option for IR), reverse cycle valve, dehydrator filter, axial fans with safety protection grilles, finned coil made of copper pipes and aluminium louvered fins with subcooling section. The circuit is protected by a safety gas valve, high and low pressure switches and differential pressure switch on the heat exchanger. The heat exchanger and all the hydraulic pipes are thermally insulated in order to avoid condensate generation and to reduce thermal losses.

All the units can be equipped with variable speed fans control that allows the units to operate with low outdoor temperatures in cooling and high outdoor temperature in heating and permits to reduce noise emissions in such operating conditions.

The low noise acoustic setting up (AS) is obtained, starting from the base setting up (AB), reducing the rotational speed of the fans and mounting sound jackets on the compressors and the technical compartment is clad with soundproofing material of suitable thickness.

The eXtra low noise acoustic setting up (AX) is obtained, starting from the low noise setting up (AS), further reducing the rotational speed of the fans and using finned coil with bigger surface.

All the units are supplied with a management and control electrical panel containing general switch, phase presence and correct sequence controller, microprocessor controller with display and all the other electrical components with IP54 minimum protection degree.

All the units are accurately built and individually tested in the factory. Only electric and hydraulic connections are required for installation.

Options

Storing module available in the configurations :

- 1 or 2 pumps
- standard or high head pump
- modulating pump

Expansion valve

- thermostatic
- electronic (standard for IP)

Compressor starting

- standard (contactors)
- soft starter

Fans control

- on-off control
- modulating control (condensation / evaporation control)

Compressor power factor correction

Electrical load protection

- fuses
- thermal magnetic circuit breakers

Coil condensate tray

Accessories

Rubber vibration dampers

Spring vibration dampers

Coil protection grilles

Remote control

Modbus serial interface on RS485

Programmer clock

Phase sequence and voltage controller

Low temperature kit (standard for IP)

High and low pressure gauges

High temperature thermostat

Coil shut off valves

Outdoor air sensor

Water flow switch

Vicia hydraulic fittings

Acoustic performances

Base setting up (AB)	40.2	50.2	60.2	70.2	80.2	90.2	100.2	115.2	130.2	145.2	160.2	180.2	200.2	
Sound power level	82	82	83	84	84	85	85	85	86	87	87	88	88	dB(A)
Sound pressure level at 1 meter	64	64	65	66	66	67	67	67	68	69	69	69	69	dB(A)
Sound pressure level at 5 meters	55	55	56	57	57	58	58	58	59	60	60	61	61	dB(A)
Sound pressure level at 10 meters	50	50	51	52	52	53	53	53	54	55	55	56	56	dB(A)
Low noise setting up (AS)	40.2	50.2	60.2	70.2	80.2	90.2	100.2	115.2	130.2	145.2	160.2	180.2	200.2	
Sound power level	79	79	80	81	81	82	82	82	83	84	84	85	85	dB(A)
Sound pressure level at 1 meter	61	61	62	63	63	64	64	64	65	66	66	66	66	dB(A)
Sound pressure level at 5 meters	52	52	53	54	54	55	55	55	56	57	57	58	58	dB(A)
Sound pressure level at 10 meters	47	47	48	49	49	50	50	50	51	52	52	53	53	dB(A)
eXtra low noise setting up (AX)	40.2	50.2	60.2	70.2	80.2	90.2	100.2	115.2	130.2	145.2	160.2	180.2	200.2	
Sound power level	77	77	78	79	79	80	80	80	81	82	82	83	83	dB(A)
Sound pressure level at 1 meter	59	59	60	61	61	62	62	62	63	64	64	64	64	dB(A)
Sound pressure level at 5 meters	50	50	51	52	52	53	53	53	54	55	55	56	56	dB(A)
Sound pressure level at 10 meters	45	45	46	47	47	48	48	48	49	50	50	51	51	dB(A)

The acoustic performances are referred to units operating in cooling mode at nominal conditions A35W7.

Unit placed in free field on reflecting surface (directional factor equal to 2).

The sound power level is measured according to ISO 9614 standard.

The sound pressure level is calculated according to ISO 3744 and is referred to a distance of 1/5/10 metres from the external surface of the unit.

Technical data

Unit	40.2	50.2	60.2	70.2	80.2	90.2	100.2	115.2	130.2	145.2	160.2	180.2	200.2	
Power supply	400 - 3+N - 50						400 - 3 - 50						V-ph-Hz	
Compressor type	scroll													-
N° compressors / N° refrigerant circuits	2 / 1													n°
Plant side heat exchanger type	shell and tube													-
Source side heat exchanger type	finned coil													-
Fans type	axial													-
N° fans	2	3			2			3	4			n°		
Water volume plant side heat exchanger	9,5	15,3			21,7			29,2	37,8			l		
Hydraulic fittings plant side heat exchanger	2" GAS M			2" ½ GAS M			3" GAS M						-	

Electrical data

Standard unit	40.2	50.2	60.2	70.2	80.2	90.2	100.2	115.2	130.2	145.2	160.2	180.2	200.2	
FLA - Full load current at maximum tolerated conditions	40,2	45,7	53,3	58,7	69,6	75,5	90,0	97,9	106	123	136	159	170	A
FLI - Full load power input at maximum tolerated conditions	21,6	24,4	28,4	31,0	36,2	44,0	55,0	60,5	66,0	75,7	83,3	95,4	103	kW
MIC - Maximum instantaneous current of the unit	134	143	149	173	213	264	259	267	267	348	361	355	391	A
MIC SS - Maximum instantaneous current of the unit with soft starter options	89,3	96,3	101	117	143	174	175	183	183	200	246	248	272	A
Unit with high head modulating pump	40.2	50.2	60.2	70.2	80.2	90.2	100.2	115.2	130.2	145.2	160.2	180.2	200.2	
FLA - Full load current at maximum tolerated conditions	46,3	51,8	59,4	64,8	76,0	81,6	96,1	107	115	132	147	169	180	A
FLI - Full load power input at maximum tolerated conditions	25,1	27,9	31,9	34,5	42,1	47,5	58,5	65,1	70,6	80,3	89,6	102	109	kW
MIC - Maximum instantaneous current of the unit	140	150	155	179	219	270	265	276	276	357	372	365	402	A
MIC SS - Maximum instantaneous current of the unit with soft starter options	95,4	102	107	123	150	180	181	192	192	209	257	258	282	A

Operative range

Temperature	Unit type	Cooling		Heating		
		min	max	min	max	
Outdoor air inlet temperature	IR, BR, IP, BP	-10*	52**	-10	40*	(°C)
Water outlet temperature	IR, IP	5	15	30	55	(°C)
Water outlet temperature	BR, BP	-12	5	30	55	(°C)
Water outlet temperature (VD)	IR, BR, IP, BP	30	70	30	70	(°C)
Water outlet temperature (VR)	IR, BR	30	55	-	-	(°C)

* with fans modulating control option (condensation / evaporation control)

** with ATC outdoor high temperature protection function

VD and VR versions

These units allow to recover the heating power, otherwise wasted on air, through an additional plate heat exchanger. The **Desuperheater Version (VD)** allow the hot water production at temperatures between 30 and 70°C through the partial heat recovery of the condensation heat. **The Total Recovery Version (VR)** allows the cold water production and, at the same time, the hot water production at temperatures between 30 and 55°C through the total recovery of the condensation heat.

Desupeheater Version (VD) - NET NOMINAL performances

IR	Base setting up (AB)	40.2	50.2	60.2	70.2	80.2	90.2	100.2	115.2	130.2	145.2	160.2	180.2	200.2	
A35W7 - W45	Cooling capacity	46,8	55,1	60,3	71	81,1	93,8	105	115	130	148	163	185	206	kW
	Total power input	15,3	18,3	20,3	23,4	27,3	31,8	35,1	38,9	44	50,3	55,8	63	69,9	kW
	EER	3,05	3	2,98	3,03	2,97	2,95	2,99	2,96	2,95	2,94	2,92	2,94	2,95	W/W
	HRE	3,93	3,86	3,84	3,88	3,83	3,8	3,86	3,85	3,83	3,81	3,8	3,82	3,83	W/W
	Water flow rate	2,25	2,66	2,91	3,42	3,91	4,52	5,06	5,54	6,26	7,12	7,84	8,93	9,94	l/s
	Water pressure drop	25	36	30	41	52	47	59	69	50	62	76	51	62	kPa
	Heating recovery capacity	13,5	15,7	17,6	20	23,6	27,1	30,4	34,4	38,4	44	49,3	55,4	61,3	kW
	Water flow rate recovery	0,65	0,75	0,84	0,96	1,13	1,29	1,45	1,64	1,83	2,1	2,36	2,65	2,93	l/s
	Water pressure drop recovery	6	9	11	14	19	15	18	11	14	18	22	18	21	kPa
	A35W7 - W45	IP Base setting up (AB)	40.2	50.2	60.2	70.2	80.2	90.2	100.2	115.2	130.2	145.2	160.2	180.2	200.2
Cooling capacity		45,3	54,5	59,3	69,3	76,5	92,1	102	113	126	143	159	183	204	kW
Total power input		15,1	18,5	20,1	23,5	26,4	31,5	34,9	38,7	43,4	49,1	54,9	62,1	69,5	kW
EER		3	2,94	2,94	2,95	2,9	2,92	2,93	2,92	2,9	2,91	2,89	2,95	2,94	W/W
HRE		3,86	3,76	3,79	3,78	3,77	3,75	3,77	3,78	3,76	3,77	3,75	3,8	3,77	W/W
Water flow rate		2,18	2,63	2,86	3,34	3,68	4,43	4,92	5,45	6,07	6,88	7,64	8,84	9,84	l/s
Water pressure drop		23	35	29	38	47	45	54	67	47	59	73	50	61	kPa
Heating recovery capacity		13	15,2	17	19,4	22,9	26,2	29,2	33,2	37,1	42,4	47,5	52,4	58,1	kW
Water flow rate recovery		0,62	0,73	0,81	0,93	1,09	1,25	1,4	1,59	1,77	2,03	2,27	2,5	2,78	l/s
Water pressure drop recovery		6	8	10	13	18	14	17	10	13	17	21	16	19	kPa

Total Recovery Version (VR) - NET NOMINAL performances

IR	Base setting up (AB)	40.2	50.2	60.2	70.2	80.2	90.2	100.2	115.2	130.2	145.2	160.2	180.2	200.2	
A35W7 - W45	Cooling capacity	46,8	55,1	60,3	71	81,1	93,8	105	115	130	148	163	185	206	kW
	Total power input	13,9	16,9	18,4	21,4	25,3	27,9	31,1	35	40	44,4	49,9	55,3	62,1	kW
	EER	3,36	3,25	3,28	3,31	3,2	3,36	3,38	3,29	3,25	3,33	3,26	3,35	3,32	W/W
	HRE	7,67	7,46	7,52	7,58	7,35	7,67	7,71	7,52	7,45	7,61	7,47	7,65	7,59	W/W
	Water flow rate	2,25	2,66	2,91	3,42	3,91	4,52	5,06	5,54	6,26	7,12	7,84	8,93	9,94	l/s
	Water pressure drop	25	36	30	43	52	50	59	69	50	64	76	52	64	kPa
	Heating recovery capacity	60	71,2	77,8	91,4	105	120	135	148	168	190	210	238	265	kW
	Water flow rate recovery	2,87	3,4	3,72	4,37	5,02	5,73	6,45	7,07	8,03	9,08	10	11,4	12,7	l/s
	Water pressure drop recovery	35	49	41	45	50	48	52	47	52	51	52	55	55	kPa

Data declared according to **EN 14511**. The values are referred to units without options and accessories.
EER (Energy Efficiency Ratio) = ratio of the total cooling capacity to the effective power input of the unit
HRE (Heat Recovery Efficiency) = ratio of the total capacity of the system (heating plus cooling capacity) to the effective power input
A35W7 - W45 = source : air in 35°C d.b. / plant : water in 12°C out 7°C / Recovery : water in 40°C out 45°C

CONTROL SYSTEM

The units are equipped with a controller designed to ensure energy saving and unit efficiency. Available functions :

- Adaptive function
- Dynamic defrost
- Sound management
- Climatic control in heating and in cooling mode
- Economy function
- Demand limit
- Integrative heating
- Remote stand by
- Remote cooling-heating



DIMENSIONS - MINIMUM OPERATING AREA - WEIGHT

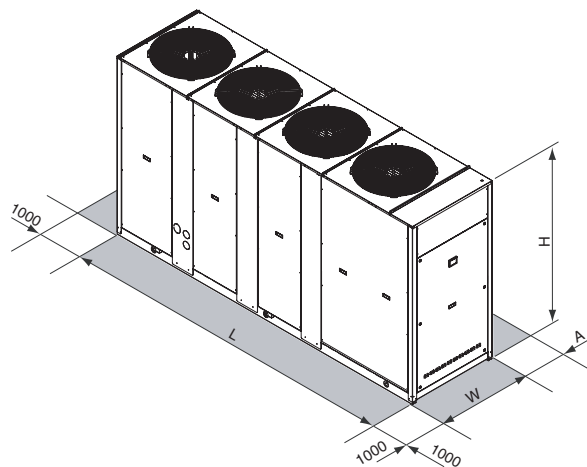

	40.2	50.2	60.2	70.2	80.2	90.2	100.2	115.2	130.2	145.2	160.2	180.2	200.2	
L			2501				3343			3343			4097	mm
W			954				1104			1104			1104	mm
H			1930				1793			2193			2193	mm
A			1600							2000				mm
Operating maximum weight*	791	793	844	876	893	1197	1278	1414	1465	1522	1561	1784	1812	kg

* Weight refers to the unit IP complete wuth 2 pumps module without tank.